

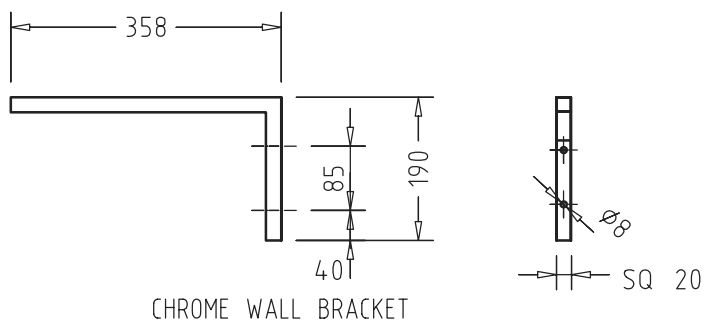

500400-F

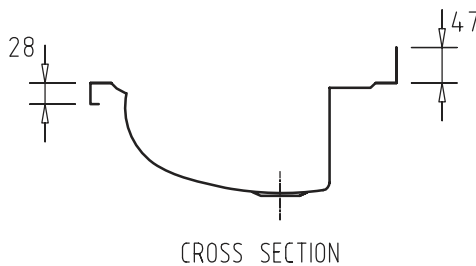
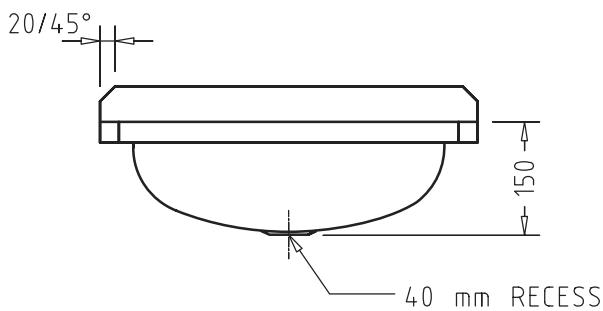
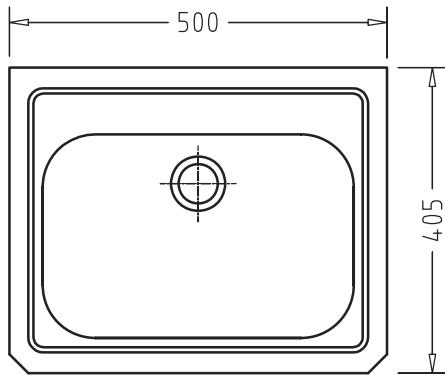

## HAND BASINS

Product Code 500400-F-0TCOM

500400-F-1TCOM

500400-F-2TCOM

500400-F-3TCOM

### Features and benefits

- Economical
- Stylish design
- Seamless construction
- Chamfered corners

### Product information

Woodroffe Standard 500x400 Wash Basins are the ideal solution for washrooms, toilets or kitchens where the functionality of stainless steel is required.

The chamfered corners offer a unique safety feature while the the versatility of these units makes them practical for use in any application.

All wash basins are supplied complete with wall brackets and plug and waste.



Woodroffe Equipment Australia

Toll free Ph 1300 361 053

Toll free Fax 1300 139 707

www.woodroffe.com.au