

TREAD MOUNT URINAL**Product Code** URTF**Features and benefits**

- Concealed vandal resistant sparge
- Full face flushing features
- 25mm radius to all internal corners
- Unique water distribution butterfly concealed in sparge
- Vandal resistant stainless steel hinged grate
- Top or Back inlet available

Product information

Woodroffe Tread Mount Urinals are manufactured from 1.2 304#4 stainless steel, are available in a full range of standard sizes or can be custom made to order. The grates are manufactured from round solid rod and are the most hygienic on market. These urinals are available with left, right or centre waste and with a full range of accessories including free standing end panels and flush pipes.

Standard features include 1:80mm fall to outlet, 1:100mm batter on rear face, 1 outlet per 5m and 1 inlet per 2.4m.

When ordering please specify Length, Outlet position and Outlet size (50, 65 or 100mm).

Standard Sizes

- 1200
- 1500
- 1800
- 2100
- 2400

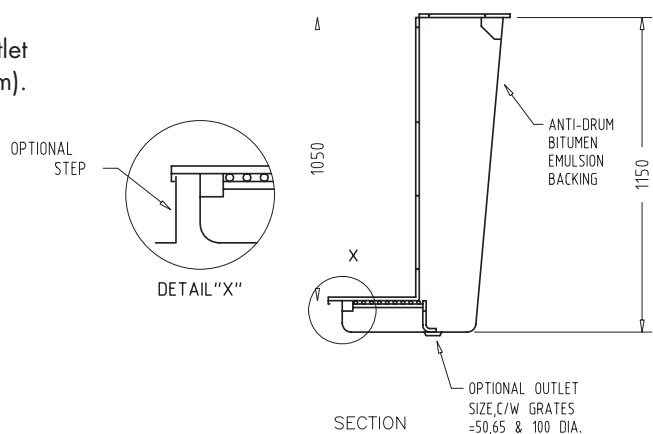
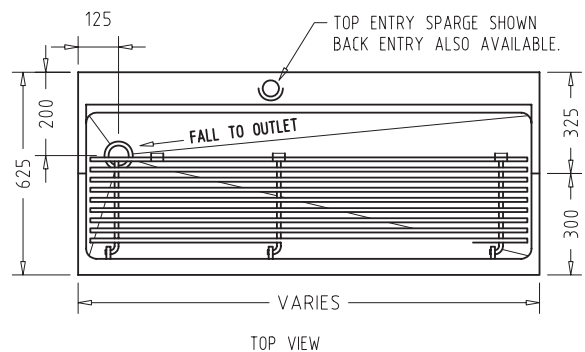

A Hills Company



Woodroffe Equipment Australia
Toll free Ph 1300 361 053
Toll free Fax 1300 139 707
www.woodroffe.com.au