

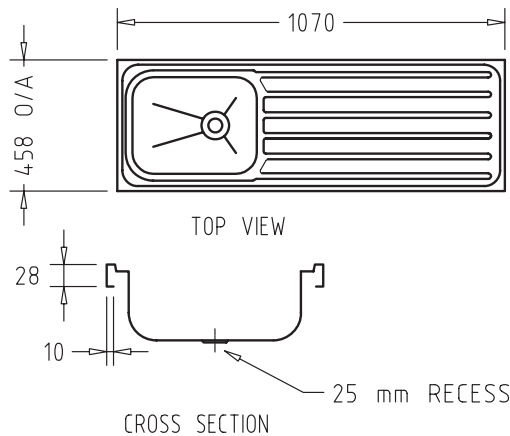

FS10-1S

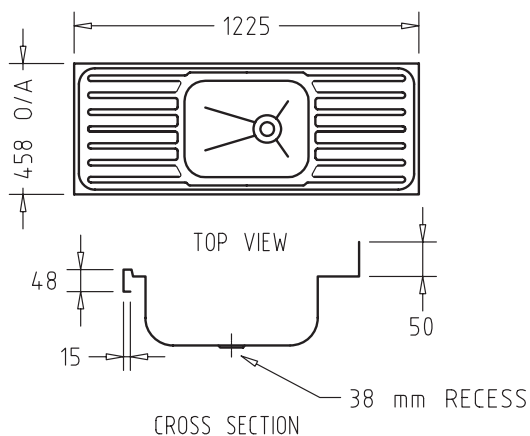

FS10-2S



### FLUTELINE SINKS

**Product Code** FS10-1S  
FS10-2S

#### Features and benefits

- Economical
- Stylish design
- Seamless construction
- Deep anti-spill edges
- Contour design bowls

#### Product information

The Fluteline range of stainless steel benches is unique in every way. It's an inexpensive solution for any kitchen environment. Fluteline benches are suitable for commercial work areas, domestic kitchens, transportable buildings, motor home, boats and caravans.

Combining complete seamless construction, deep anti spill edges and contour design bowls these features ensure benches that are better draining with extra bowl capacity plus the easy-to-clean hygienic characteristics, ensured by stainless steel.



Woodroffe Equipment Australia  
Toll free Ph 1300 361 053  
Toll free Fax 1300 139 707  
[www.woodroffe.com.au](http://www.woodroffe.com.au)



10-5S  
10-6S  
10-8S

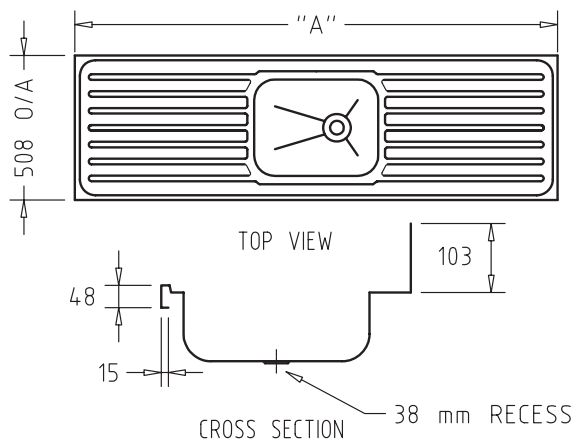

10-6D  
10-8D

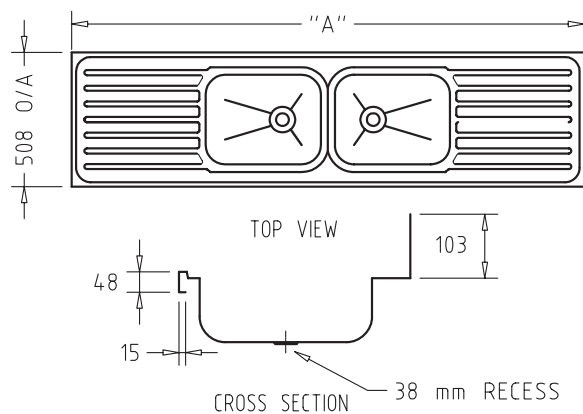

## FLUTELINE SINKS

**Product Code** FS10-5S

FS10-6S

FS10-8S

FS10-6D

FS10-8D

## Features and benefits

- Economical
- Stylish design
- Seamless construction
- Deep anti spill edges
- Contour design bowls

## Product information

The Fluteline range of stainless steel benches is unique in every way. It's an inexpensive solution for any kitchen environment. Fluteline benches are suitable for commercial work areas, domestic kitchens, transportable buildings, motor home, boats and caravans.

Combining complete seamless construction, deep anti spill edges and contour design bowls, these features ensure benches that are better draining with extra bowl capacity, plus the easy-to-clean hygienic characteristics ensured by stainless steel.



Woodroffe Equipment Australia

Toll free Ph 1300 361 053

Toll free Fax 1300 139 707

www.woodroffe.com.au